

Super-Mod® Clutch Only Modules: SM-1040, SM-1040WD (Washdown) and SM-3040B

DIMENSIONS
BACK TO TABLE OF CONTENTS
BACK TO SM PRODUCT OVERVIEW

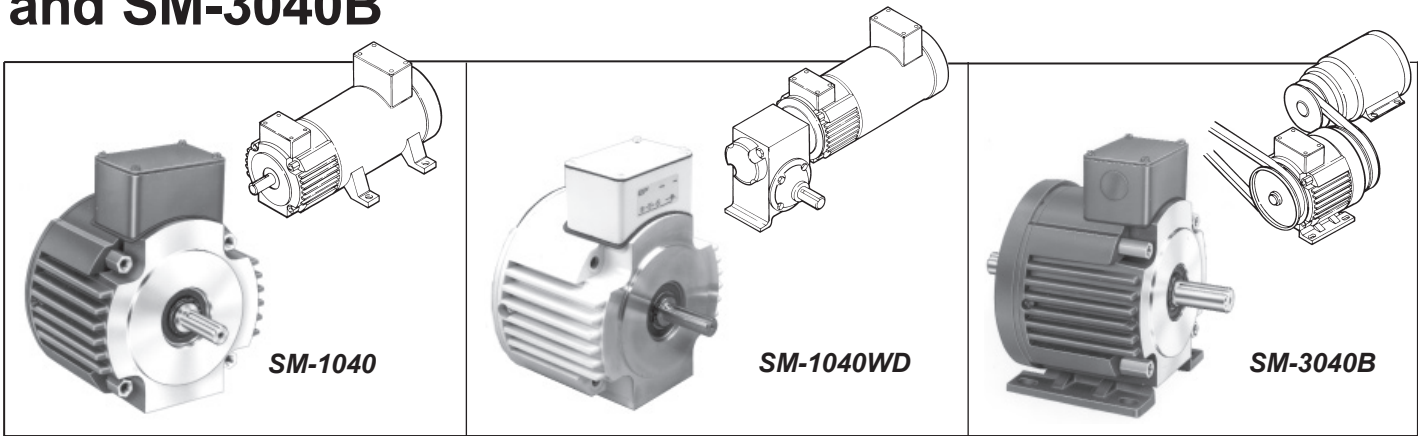

- 56C through 215TC NEMA Frame Sizes
- 16 through 145 lb-ft Static Torque; 2400 Maximum RPM
- TENV – Totally Enclosed (Non-Ventilated) IP-54 Enclosure Protection, (IP-55 for Washdown Units)
- Listed by Underwriters Laboratories, Inc., File E-71115 and CSA Certified, File LR-6254
- Maximum overhung load capacity is 85 lbs

Performance Data, Ordering Information

Static Torque lb-ft	Dynamic Torque lb-ft	NEMA Frame	Hub Bore and Shaft Diameter	Model	Part Number ^①	Thermal Capacity (ft-lb/min) ②	Wt. (lbs)	Maximum Electrical Power (watts)
16	10	56C	5/8 hub bore 5/8 shaft	SM-50-1040	2-36-0561-01-A*L	5000	20	19
				SM-50-1040B	2-36-0561-01-B*L	5000	22	19
				SM-50-1040WD	2-36-0562-01-A*L	5000	20	19
				SM-50-3040	2-36-0561-01-C*L	5000	20	19
				SM-50-3040B	2-36-0561-01-D*L	5000	24	19
				SM-100-1040	2-36-0561-02-A*L	5000	20	29
				SM-100-1040B	2-36-0561-02-B*L	5000	22	29
				SM-100-1040WD	2-36-0562-02-A*L	5000	22	29
				SM-100-3040	2-36-0561-02-C*L	5000	22	29
				SM-100-3040B	2-36-0561-02-D*L	5000	24	29
35	20	140TC	7/8 hub bore 7/8 shaft	SM-180-1040	2-36-1401-02-A*O	5000	20	29
				SM-180-1040B	2-36-1401-02-B*O	5000	22	29
				SM-180-1040WD	2-36-1402-02-A*O	5000	20	29
				SM-180-3040	2-36-1401-02-C*O	5000	22	29
				SM-180-3040B	2-36-1401-02-D*O	5000	24	29
75	44	180TC	1-1/8 hub bore 1-1/8 shaft	SM-210-1040	2-36-1801-03-A*R	7000	31	16
				SM-210-1040B	2-36-1801-03-B*R	7000	31	16
				SM-210-3040	2-36-1801-03-C*R	7000	31	16
				SM-210-3040B	2-36-1801-03-D*R	7000	31	16
145	86	210TC	1-3/8 hub bore 1-3/8 shaft	SM-250-1040	2-36-2101-04-A*U	5600	31	38
				SM-250-1040B	2-36-2101-04-B*U	5600	31	38
				SM-250-3040	2-36-2101-04-C*U	5600	31	38
				SM-250-3040B	2-36-2101-04-D*U	5600	31	38

②Thermal capacity rating is based on ambient temperature of 70°F at 1750 RPM.

Voltage Table

Character	Voltage
C	12 Vdc
E	24-28 Vdc
J	90-100 Vdc
N	115 Vac
P	230 Vac

Hub Size Table for SM-1040's

Character	Bore	Keyway
L	5/8	3/16 x 3/32
O	7/8	3/16 x 3/32
R	1 1/8	1/4 x 1/8
U	1 3/8	5/16 x 5/32

Options - Features Table

Series	Character	Description
SM-1040	A	Basic unit
SM-1040B	B	Basic unit plus base
SM-3040	C	Basic unit plus clutch input adapter
SM-3040B	D	Basic unit plus base & clutch input adapter

Specials available upon request.

SM Clutch Module Guide:

SM-1040 – Standard (direct-coupled)
 SM-1040B – Standard with Base
 SM-1040WD – IP-55 Washdown (available in NEMA frame sizes 56C-145TC)
 SM-3040 – Standard with Clutch Input Adapter
 SM-3040B – Clutch Input Adapter Plus Base

①Example of a complete part number:

2-36-0561-01-AJL — 5/8 hub
 — 90-100 Vdc
 — Basic unit
 — 0=Standard Unit
 — 2= Without Gap Adjust